



Figure # 5595W
Brass Solder End Ball Valve (1/2"-2")

Product Features

- 150#WSP / 600# WOG
- Forged Brass Body
- Full Port
- Adjustable Packing
- Solder Ends
- Blowout Proof Stem
- Wing Handle



Certified to
ANSI/NSF 61



Handle cut away for illustrative purposes. Actual handle type shown above.

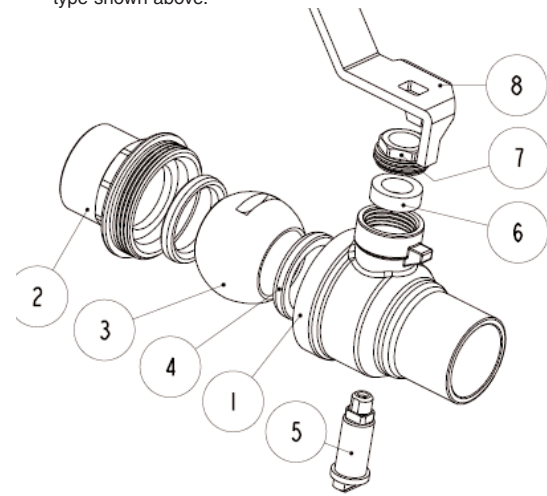

Pressure/Temperature Ratings	
600 PSI from 15F to 160F	150 PSI MAX at 366F

Materials & Specifications

Item	Description	Material	Specification
1	Body	Brass	B283 C37700
2	End Piece	Brass	B283 C37700
3	Ball	Brass/Chrome Plated	B283 C37700
4	Seat	PTFE	PTFE
5	Stem	Brass	B124 C37700
6	Packing	PTFE	PTFE
7	Packing Nut	Brass	B124 C37700
8	Wing Handle	Zinc plated steel	A36 Dacromet
9	Handle Nut	Zinc plated steel	A36 Dacromet

Dimensions, Weights (inches-lbs.) & Valve Data

Size	1/2	3/4	1	1-1/4	1-1/2	2
A	2.5	2.5	3.2	3.2	3.9	3.9
H	1.7	1.9	2.3	2.5	2.8	3.2
L	2	2.7	3.3	3.8	4.2	5.3
Cv	15	30	60	110	130	360
Wt.- lbs.	.4	.6	1.1	1.4	2.3	3.5

