



ECO-VALVE

Figure # 5544DAB

Low Lead Brass Ball Valve (1/4"-4")

Product Features

- 150# WSP / 600# WOG
- Forged Brass Body
- Full Port
- Adjustable Packing
- Blow-Out Proof Stem
- MSS-SP-110
- CSA 1/2 & 5 PSI (1/4"-3")
- UL Approved 1/2"-2"
- FM Approved 1/2"-2"
- AB1953 Certified
- Domestic valve



Certified to ANSI/NSF 61



Pressure/Temperature Rating	
600 PSI from 15°F to 160°F	150 PSI MAX at 366°F

Materials & Specifications

Item	Description	Material	Specification
1	Body	Low Lead Brass	CW510L
2	End piece	Low Lead Brass	CW510L
3	Ball	Low Lead Brass/Cr Plated	CW510L
4	Seat	PTFE	PTFE
5	Stem	Low Lead Brass	CW510L
6	Packing	PTFE	PTFE
7	Packing nut	Brass	B124 C37700
8	Handle	Dacromet Steel	A36 Dacromet
9	Handle nut	Zinc Plated Steel	A36
10	Valve info	-	-

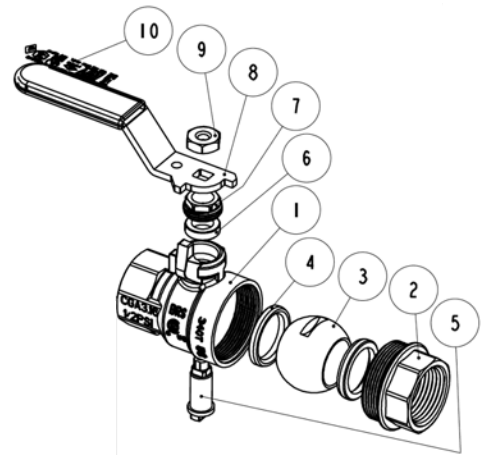

Dimensions, Weights (inches-lbs.) & Valve Data

Size	3/8	1/2	3/4	1	1-1/4	1-1/2	2	2-1/2	3	4
A	1.73	2.13	2.45	2.85	3.28	3.80	4.34	5.91	6.82	7.56
C	0.45	0.55	0.59	0.71	0.73	0.77	0.81	1.18	1.22	1.32
H	1.54	2.10	2.24	2.57	2.78	3.27	3.56	4.68	5.13	5.64
L	3.19	3.60	3.60	4.98	4.98	5.57	5.57	11.07	11.07	11.07
P	0.39	0.59	0.79	0.98	1.26	1.57	1.97	2.56	3.15	3.94
Cv	8	15	30	60	110	130	360	450	620	1200
Wt	0.25	0.50	0.70	1.20	1.70	2.80	4.00	8.30	11.30	17.20

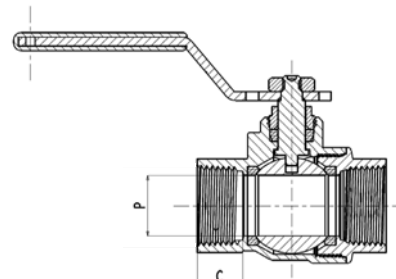
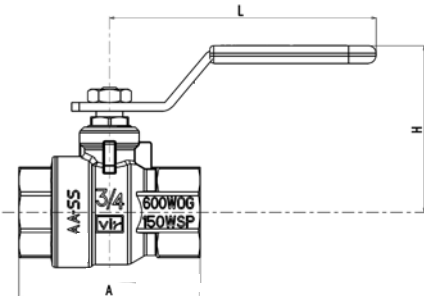

RED-WHITE VALVE CORP.

20600 Regency Lane, Lake Forest, CA 92630

TEL: 949.859.1010 • FAX: 949.859.7200 • www.redwhitevalvecorp.com