



Figure # 5042

Auto Drain Brass Ball Valve (1/2"-2")

Product Features

- 600# WOG
- Forged Brass Body
- Full Port
- Automatic Drain Port in Body
- Adjustable Packing
- Threaded Ends
- Blowout Proof Stem
- Locking Lever Handle
- MSS-SP-110
- NSF61-8 Certified 1/2"-2"



Certified to
ANSI/NSF 61

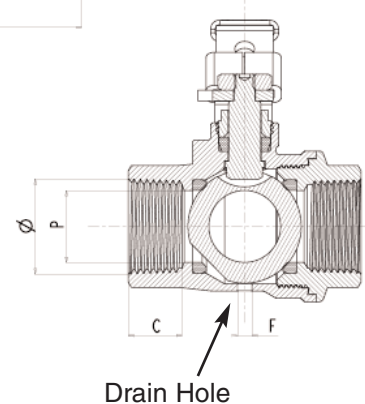
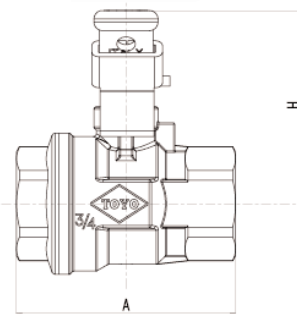
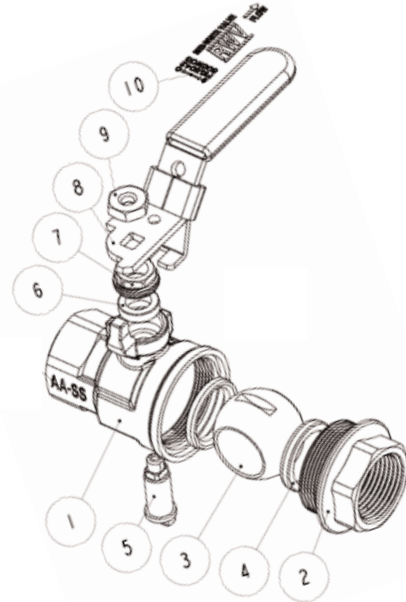

Drain Hole

Pressure/Temperature Rating

600 PSI from 15F to 140F

Materials & Specifications

Item	Description	Material	Specification
1	Body	Brass	B283 C37700
2	End Piece	Brass	B283 C37700
3	Ball	Brass/Chrome Plated	B283 C37700
4	Seat	PTFE	PTFE
5	Stem	Brass	B124 C37700
6	Packing	PTFE	PTFE
7	Packing Nut	Brass	B124 C37700
8	Handle	Zinc plated steel	A36 Dacromet
9	Handle Nut	Zinc plated steel	A36 Dacromet
10	I.D. Information	N/A	N/A

Dimensions, Weights (inches-lbs.) & Valve Data

Size	1/2	3/4	1	1-1/4	1-1/2	2
A	2.13	2.56	2.91	3.39	3.90	4.45
C	.55	.59	.71	.73	.77	.81
H	2.13	2.26	2.57	2.79	3.28	3.58
L	3.6	3.6	4.98	4.98	5.57	5.57
P	.59	.79	.98	1.26	1.57	1.97
Cv	15	30	60	110	130	360
Wt.- lbs.	.6	.85	1.4	2.1	3.1	5
Drain Size	.16	.16	.16	.16	.16	.16

