



**Figure # 452**

Cast Iron Dual Plate Check Valve (2"-12")

**Product Features**

- 150# WOG
- Iron Body
- Dual Plate Discs
- Wafer Style Body
- Nickel Plated Ductile Discs
- Buna Seat



Pressure/Temperature Ratings	
150# WOG	180 degrees F. max temp.

**Materials & Specifications**

Item	Description	Material	Specification
1	Body	Cast Iron	A126 Class B
2	Disc (Plate)	Ductile Iron (Nickel Plated)	A216
3	Spring	Stainless Steel	A313 - 316
4	Pin	Stainless Steel	A276 - 304
5	Plug	Steel	A576 1025
6	Plate Washer	PTFE	-
7	Body Washer	PTFE	-
8	Spring Washer	PTFE	-
9	Eye Bolt (6"-12")	Steel	A307 -A
10	Seat	Buna-N	-

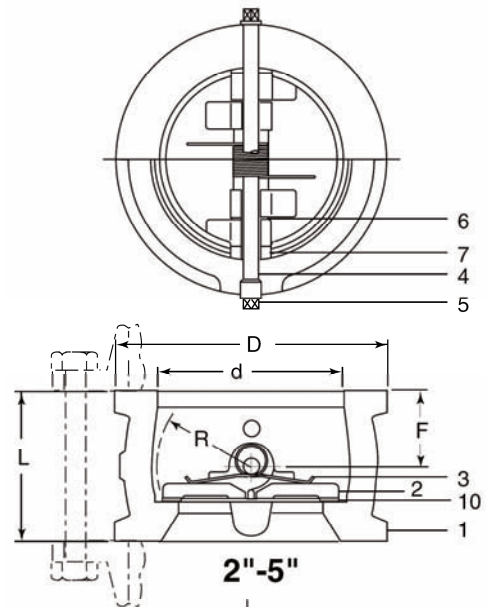

**Dimensions, Weights (inches-lbs.) & Valve Data**

Size	2	2-1/2	3	4	5	6	8	10	12
d	2.4	2.88	3.51	4.49	5.55	6.62	8.63	10.75	12.76
D	4.14	4.88	5.39	6.89	7.76	8.74	10.19	13.39	16.15
F	1.06	1.06	1.18	1.26	1.30	1.38	1.65	1.65	2.28
L	2.13	2.13	2.25	2.52	2.76	2.99	3.74	4.25	5.63
R	1.26	1.46	1.77	2.08	2.64	3.11	4.14	5.04	6.11
Wt.- lbs.	6.6	8.8	11	13.2	20	22	45	68	123

