



Figure # 281
Bronze Solder End Gate Valve

Product Features

- 125# WSP / 200# WOG
- Bronze Body
- Solder Ends
- Inserted Bonnet
- Non-Rising Stem
- Solid Disc
- MSS-SP-80
- NSF to 2"



Materials & Specifications

Item	Description	Material	Specification
1	Body	Cast Bronze	B62-C83600
2	Bonnet	Cast Bronze	B62-C83600
3	Disc	Cast Bronze	B62-C83600
4	Stem	Brass	DR Alloy
5	Stuffing Box	Brass	B16-C36000
6	Packing Nut	Size 4" Brass	B283-C37700
7	Gland	Brass	B124-C37700
8	Gland Packing	Plastic/Graphite	T#2996NA
9	Handwheel	3/4" - 2" Alum. Alloy	B85-SC114A
9	Handwheel	1/2 Zinc Alloy	B86-AG40A
10	Wheel Nut	Zinc Plated	A36
11	Name Plate	Aluminum	B209-1100

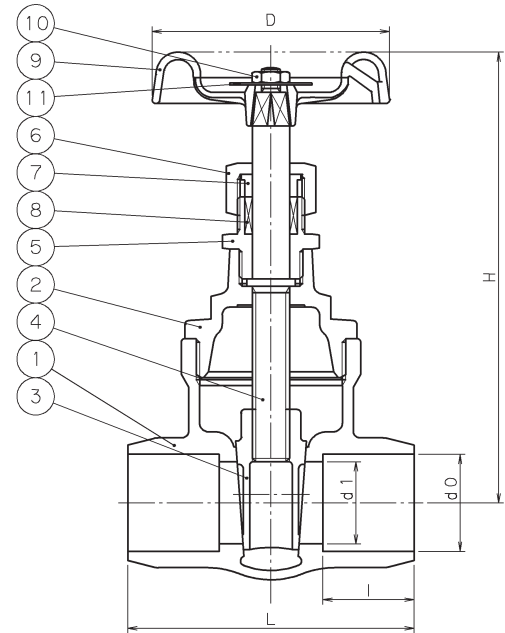

Dimensions & Weights (inches-lbs.)

Size	3/8	1/2	3/4	1	1-1/4	1-1/2	2	2-1/2	3	
D	1.89	2.17	2.48	2.76	3.15	3.54	3.94	4.33	4.92	
dO	min.	.502	.627	.877	1.128	1.378	1.628	2.128	2.628	3.128
	max.	.506	.631	.881	1.132	1.382	1.633	2.133	2.633	3.133
d1	.39	.59	.79	.98	1.26	1.58	1.97	2.5	2.99	
H	3.58	3.78	4.33	4.88	5.63	6.46	7.60	9.29	10.71	
I	.38	.50	.75	.91	.97	1.09	1.34	1.47	1.66	
L	1.63	1.89	2.56	2.99	3.23	3.62	4.33	4.69	5.25	
Cv	5.7	12	26	42	72	120	210	335	486	
Wt.- lbs.	.49	.77	1.10	1.61	2.36	3.42	5.38	7.83	11.42	

