

Time Is Money.

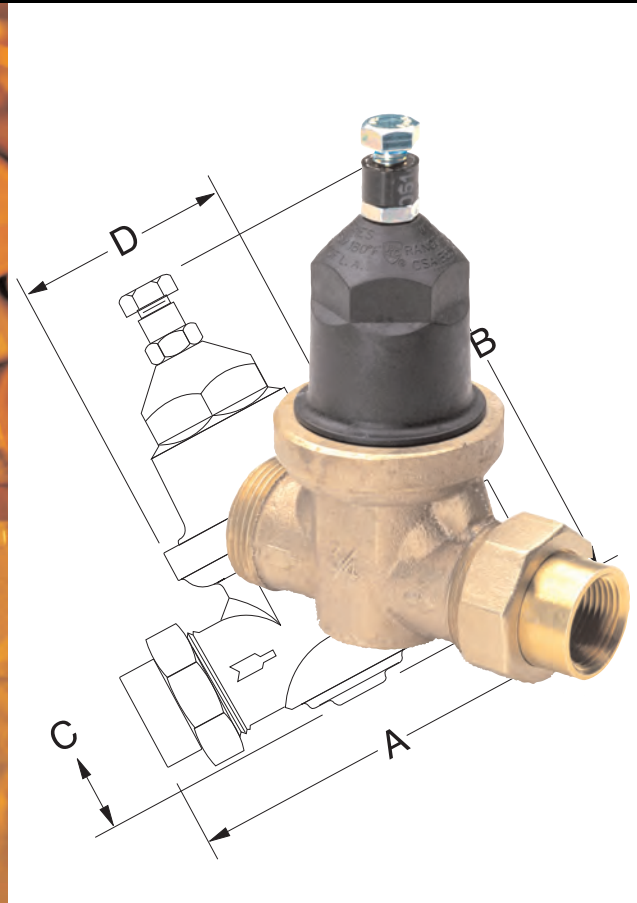

6000 Series Pressure Reducing Valves

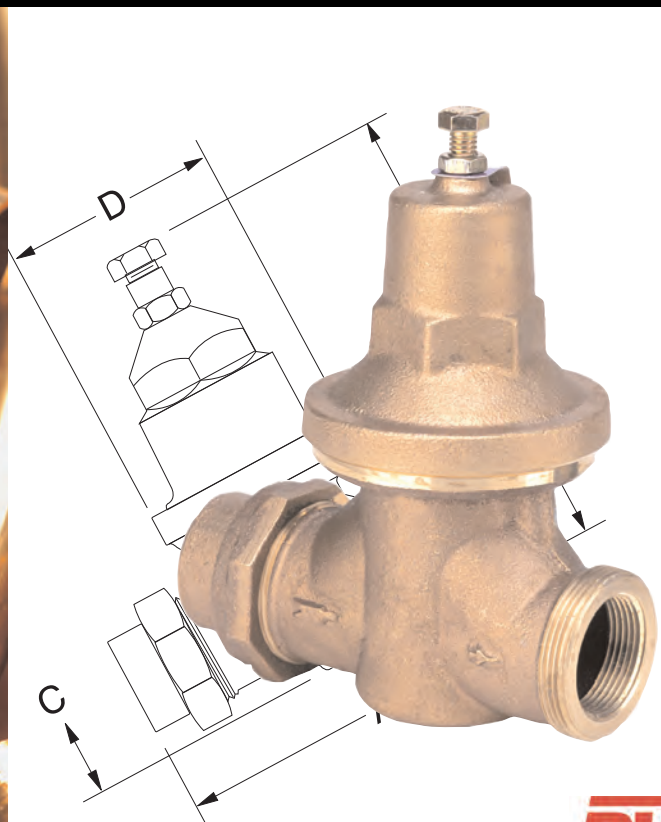

RWV

Leaders In Valve Technology

A Complete Regulator Package



- Sizes 1/2" through 2"
- Bronze Body
- Composite Bell 1/2"- 1-1/4"
- Bronze Bell 1-1/2" - 2"
- Integral Overpressurization Bypass
- Stainless Adjustment bolt & Lock Nut standard
- Removable Stainless Steel Mesh Strainer
- Reduced Pressure range from 15psi to 75psi
- Factory preset at 50psi
- Durable FDA approved EPDM & BUNA elastomers
- ASSE listed
- IAPMO listed
- CSA certified*

Product Advantages

The series 6000 Pressure Reducing Valves (Regulators) are a complete self-contained solution to reduce excessive inlet pressures on potable water systems, thus ensuring longer piping system life and reducing the chance of damage to expensive components and fixtures.

An integral direct acting by-pass design prevents the buildup of excessive system pressure caused by thermal expansion. The internal strainer makes the 6000 series suitable for residential and commercial water systems.

The 6000 series valves are available in bare, single or double union, threaded and solder ends.

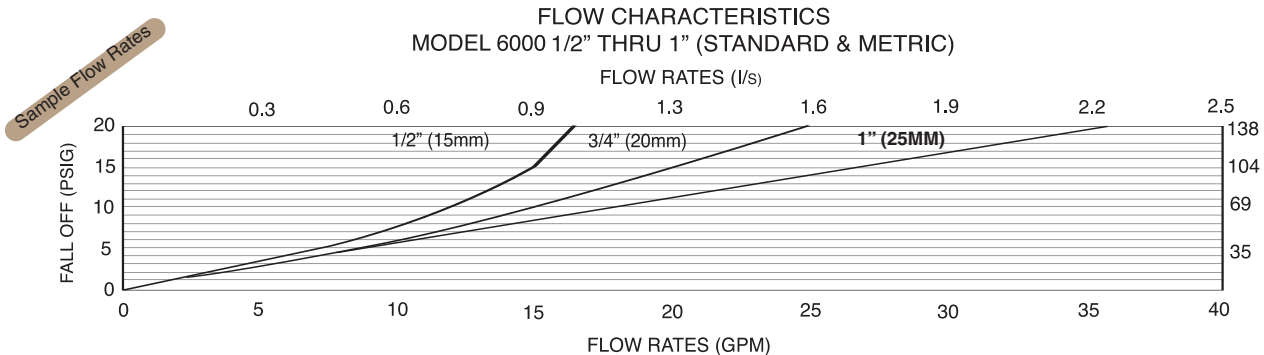

As a part of the Red-White family of problem solving products, the 6000 series valves provides you with the quality you have come to expect from the leaders in valve technology backed by a 3-year warranty and a 98% guaranteed fill rate.

Company Overview

For nearly 35 years, Red-White Valve has manufactured top quality valves and associated products for the plumbing, commercial and industrial marketplaces. Known for our quality products and unparalleled customer service, we take pride in being a leader in valve technology.

Not only do we manufacture the majority of our products in company owned facilities, each product we sell is backed by a three year warranty. RWV products are available through distributors and warehouse locations throughout North America and supported by experienced product experts both at our headquarters and in field sales offices.

When you are looking for a reliable product with superior quality -- turn to the leader.

*Certifications may be limited by size/configuration. Contact Red-White for more information

RED-WHITE VALVE



20600 Regency Lane • Lake Forest, CA 92630
Tel: 949.859.1010 • Fax: 949.859.7200 • www.redwhitevalveusa.com